

LED HI-PRO TEMPORARY STRING LIGHTS

50' | 100'

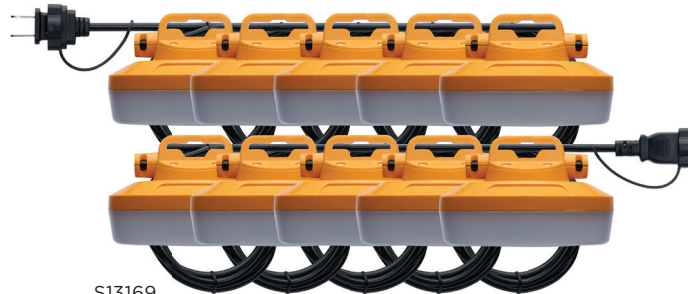

S13168



S13169



CONVENIENT HANGING HOOKS ON EACH LAMP

DURABLE 18/2 SJTW CORD

LOW PROFILE LAMPS

IMPACT RESISTANT LENS

LINK ADDITIONAL SETS FOR UP TO 300 FT. OF ILLUMINATION

SUGGESTED APPLICATIONS

- Work Area Lighting
- Construction Site Lighting
- Industrial Lighting
- Temporary Lighting

The ultimate solution for temporary lighting needs - LED Hi-Pro Temporary String Lights. Powered by an 18/2 SJTW cord, and featuring impact resistant low-profile lamps, these lights are durable enough to withstand even the harshest work environments. Whether it's construction, industrial, or temporary lighting needs, these string lights deliver exceptional performance every time. Available in 50' lengths with 5 lamps and 100' lengths with 10 lamps these sets offer versatility to suit various applications. Plus, with the ability to link multiple sets you can effortlessly customize the lighting coverage to fit your needs.



GENERAL SPECIFICATIONS

Input Voltage: 120V
Frequency: 60Hz
Power Factor: 0.9
Dimming: Non-Dimmable
Surge Protection Rating: 2kV
CCT: 5000K
Beam Angle: 360°
Efficacy: 116 LPW
CRI: 80

Location Rating: Wet
IP Rating: IP65
Ambient Operating Temperature: -30°C (-22°F) to +45°C (+113°F)
Mounting Options: Hook (carabiners Included)
Power Cord: 18AWG
Lamp Construction: Polycarbonate
Functional Life: 18,000 Hours
Warranty: 2 Years



ITEM SPECIFICATIONS / ORDER INFO

Catalog Number	Length	Number of Lamps	Lumens	Wattage	Incandescent Replacement Wattage	Input Current	Max Linkable Sets
S13168	50'	5	7000	60W	500W	0.50A	6
S13169	100'	10	14000	120W	1000W	1.00A	3

DIMENSIONS / WEIGHTS

Item	Total Length	Lamp Diameter (A)	Lamp Height (B)	Weight
S13168	600"	3.94"	1.60"	5.18 Lbs.
S13169	1200"	3.94"	1.60"	8.80 Lbs.

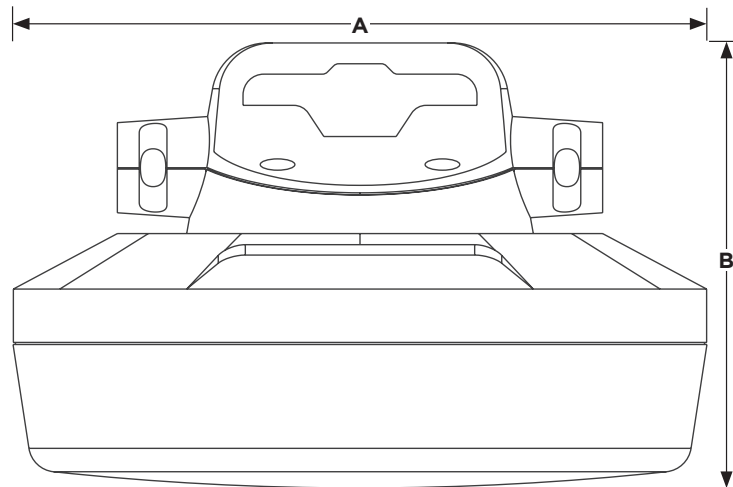

This device complies with Part 15 of the FCC Rules. Operation is subject to the following two conditions: (1) this device may not cause harmful interference, and (2) this device must accept any interference received, including interference that may cause undesired operation.

Replacement wattage shown depends on application and fixture. Specifications are subject to change without prior notice.

Warning: This product can expose you to chemicals including lead, which is known to the State of California to cause cancer and birth defects or other reproductive harm. For more information go to <http://www.P65Warnings.ca.gov>.